

SERIOUS TRUCKS



5700 XE

Extreme Efficiency Highway Tractor



Serious trucks.™



PRESENTING THE WORLD'S FIRST EXTREME EFFICIENCY TRUCK.

THE ALL-NEW WESTERN STAR® 5700XE.

When we decided to build a new fuel-efficient truck, we didn't let the industry dictate what that truck should be. We set out to create something different. Something with the tough performance and traditional look of a classic truck, but built for the modern age.

We didn't overlook a single detail along the way, combining Western Star's extreme heritage with Daimler's advanced engineering to improve efficiency, aerodynamics and profitability. And the results are nothing short of incredible.

AN EFFICIENT TRUCK THAT'S STILL ALL TRUCK. YES, THIS IS HOW WE DO AERO.

Making a profit is important. But a driver doesn't sign up with you because you run the most efficient truck. That's why we set out to build a truck that your drivers would fight over and still make your CFO smile. Or to put it another way, the 5700XE is the kind of truck that both makes you money and delivers an incredible driving experience.



CHASSIS FAIRINGS

Optional chassis side fairings significantly reduce drag while still providing easy access to your batteries and DEF tank.

STATE-OF-THE-ART HEADLIGHTS

The 5700XE's aggressively styled headlights are an exercise in engineering excellence. They're optimized for aerodynamic performance, with increased brightness for greater visibility and safety. The three-piece design reduces replacement costs, while halogen bulbs are easy to find and easy to replace at low cost.



DUAL AIR INTAKES

Our Twin Force dual air intakes feed a massive, centrally mounted air filter for improved efficiency and long service life.

AERODYNAMIC VISOR

Revolutionary in design, the 5700XE's state-of-the-art sunvisor not only drastically cuts down sun glare, it actually works with the impressive slope in the hood's rear air ramp to direct air over the cab.



POWER BY DETROIT.

Not your traditional mix-and-match offering, the Western Star 5700XE features powerful and efficient Detroit power exclusively. When these engines are coupled with Detroit™ axles and the DT12™ transmission, you get a dependable package that's engineered and designed by one manufacturer, maximizing power, fuel economy and performance while providing the industry's best driving experience – all supported and covered by a single factory warranty.

THE DETROIT ENGINE FAMILY

Detroit engines are synonymous with efficiency, power and dependability. And with the 5700XE, no matter which displacement you choose, you'll get those features matched to a truck that will take profitability to the next level.

ENGINE	HORSEPOWER	TORQUE
DETROIT™ DD13*	350-505*	1350-1850lb-ft.
DETROIT™ DD15*	400-505	1550-1750lb-ft.
DETROIT™ DD16*	500-600	1850-2050lb-ft.

DETROIT DD13



DETROIT DD15



DETROIT DD16

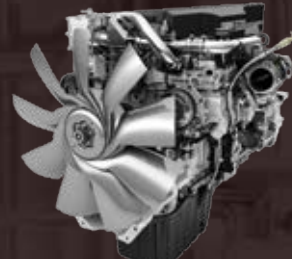

DETROIT

DETROIT™ DT12™ TRANSMISSION

With the 5700XE, our engineers examined every opportunity to reduce fuel consumption and increase efficiency. That's why the 5700XE is our first truck to feature the DT12 transmission standard. This 12-speed, direct- or over drive automated manual transmission gives you the drivability you need while optimizing fuel economy, all with the sturdy components that limit unnecessary wear and tear.

And with more new drivers coming into the market, this easy-to-operate AMT transmission helps drivers reach their optimal performance sooner while ensuring your fuel economy goals are met and your trucks continue to last for years to come.



THE BEST OF WESTERN STAR AND DAIMLER, ALL IN ONE CHASSIS.

The chassis of the 5700XE is new and proven all at the same time. Starting with a Daimler Trucks North America design with millions of miles on the road, we added those things that make a Western Star unique. Wide cab mounts for stability and comfort. Tapered frame ends for longevity. Optional Grade 8 fasteners. And the list goes on. This chassis is light, strong, and like most things Western Star, about as good as you can get.



IT'S MORE THAN AN INTEGRATED POWERTRAIN. IT'S AN INTEGRATED BUSINESS PLAN.

Every Western Star is built to make light work of even the toughest jobs. When you add the Integrated Detroit™ Powertrain to the mix, it makes light work for the accountants as well. With parts specifically engineered to work together, you can optimize performance and efficiency on the road and for your bottom line.



THE INTEGRATED DETROIT™ POWERTRAIN

All Detroit components work together and work together well. But you can take efficiency to the next level with the Integrated Detroit™ Powertrain package. This special offering combines the downsped DD15 with the direct drive DT12 transmission and specific rear axle ratios to provide the industry's most efficient powertrain package. Just goes to show that what is great can be even better.

ENGINE	HORSEPOWER	TORQUE
DETROIT DD15	400 @ 1625 RPM	1750lb-ft. @ 1075 RPM



BEAN COUNTERS AND TRUCKERS HAVE FOUND COMMON GROUND.

Read below and you can see how everything we've engineered into the all-new Western Star 5700XE is designed to increase efficiency and reduce your total cost of ownership. It's the perfect combination of proven technology and innovation from Daimler – the world's largest heavy-duty truck manufacturer – and the legendary durability, ruggedness and resale value of Western Star. That's the kind of package other OEMs can only dream about.

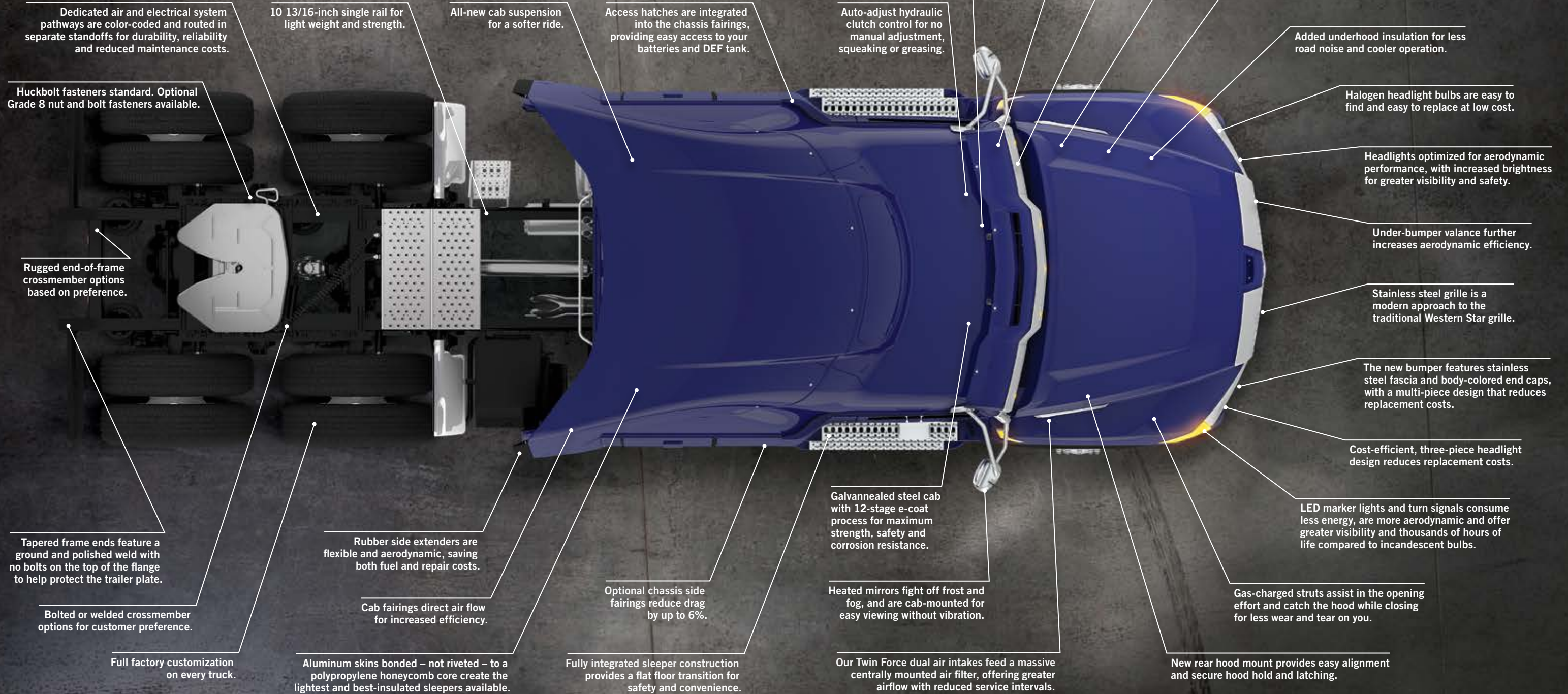

Dedicated air and electrical system pathways are color-coded and routed in separate standoffs for durability, reliability and reduced maintenance costs.

10 13/16-inch single rail for light weight and strength.

All-new cab suspension for a softer ride.

Access hatches are integrated into the chassis fairings, providing easy access to your batteries and DEF tank.

Navigational System prep provides mounting and a power source to fit a variety of nav systems.

Auto-adjust hydraulic clutch control for no manual adjustment, squeaking or greasing.

State-of-the-art visor reduces glare and decreases drag, working with the hood's rear air ramp to direct air over the cab.

Built-in LED marker lights in visor.

All fluid checks are consolidated to reduce service time.

Roped-in, two-piece windshield for faster and more cost-effective repair.

Added underhood insulation for less road noise and cooler operation.

Halogen headlight bulbs are easy to find and easy to replace at low cost.

Headlights optimized for aerodynamic performance, with increased brightness for greater visibility and safety.

Under-bumper valance further increases aerodynamic efficiency.

Stainless steel grille is a modern approach to the traditional Western Star grille.

The new bumper features stainless steel fascia and body-colored end caps, with a multi-piece design that reduces replacement costs.

Cost-efficient, three-piece headlight design reduces replacement costs.

LED marker lights and turn signals consume less energy, are more aerodynamic and offer greater visibility and thousands of hours of life compared to incandescent bulbs.

Gas-charged struts assist in the opening effort and catch the hood while closing for less wear and tear on you.

New rear hood mount provides easy alignment and secure hood hold and latching.

Huckbolt fasteners standard. Optional Grade 8 nut and bolt fasteners available.

Rugged end-of-frame crossmember options based on preference.

Tapered frame ends feature a ground and polished weld with no bolts on the top of the flange to help protect the trailer plate.

Bolted or welded crossmember options for customer preference.

Full factory customization on every truck.

Rubber side extenders are flexible and aerodynamic, saving both fuel and repair costs.

Cab fairings direct air flow for increased efficiency.

Aluminum skins bonded – not riveted – to a polypropylene honeycomb core create the lightest and best-insulated sleepers available.

Optional chassis side fairings reduce drag by up to 6%.

Fully integrated sleeper construction provides a flat floor transition for safety and convenience.

Galvanized steel cab with 12-stage e-coat process for maximum strength, safety and corrosion resistance.

Heated mirrors fight off frost and fog, and are cab-mounted for easy viewing without vibration.

Our Twin Force dual air intakes feed a massive centrally mounted air filter, offering greater airflow with reduced service intervals.

ONCE YOU GET INTO IT, IT GETS INTO YOU.

It may be a new truck, but it's a truck that's still all Western Star. A Western Star handbuilt in the United States at a new, award-winning Daimler plant, using the best Daimler technology, along with the proven Western Star components and features that make every Western Star truck an incredible value and a pleasure to drive.



DRIVER-FRIENDLY STEERING COLUMN

Our new, fully adjustable column provides a full range of motion for increased driver comfort. The new turn signal with integrated wiper and new transmission control stalk for the DT12 allow you to focus on the road ahead.



STATE-OF-THE-ART STEERING WHEEL

The new 5700XE steering wheel is available with a wood or leather-wrapped finish, and features integrated controls for the stereo, cruise control and cruise interrupt, as well as a Bluetooth® connection for mobile phones, so drivers can keep their hands on the wheel at all times.

ALL-STEEL CABS

Our galvanized steel cabs are built to keep you safe. Bonded instead of riveted, precision-welded for strength, then dipped and protected with a 12-stage e-coat process for long-lasting corrosion resistance. It's a big part of what makes a Western Star a Western Star.



ENJOY THE SILENCE

You don't often think about floor mats. We do. Our floor mat is extra thick, giving you a space with increased comfort, as well as the ability to keep out unwanted heat, cold and noise.



LIGHTWEIGHT SLEEPERS

Making the lightest sleeper on the market is only part of the reason for our space-age honeycomb construction. It provides increased insulation and sound resistance, as well as offers a superior finish and easier repair.



PREMIUM INTERIORS

You see a lot on the road. The one thing that doesn't change is your workspace. So the Western Star 5700XE is built to make it the most inviting, functional cab out there. You'll find a number of innovations – along with those things like real wood cabinets and durable Ultraleather seats that make a Western Star special – to make every day on the road an unforgettable driving experience.

SEAT FABRIC OPTIONS



Vinyl



Mordura Cloth



Ultraleather

INTERIOR COLOR OPTIONS

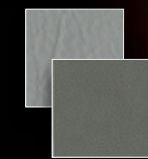

Smoky Mountain Gray

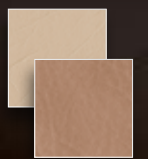

Prairie Buckskin



Pacific Forest Green



Maple Leaf Red

THE SAFEST PART OF YOUR DAY IS WHEN YOU'RE BEHIND THE WHEEL.

Starting with proven steel cabs, we've always taken safety seriously. With the 5700XE, we've taken that passion for safety several steps further.



WABCO OnGuard™ Collision Mitigation System

This radar safety system offers collision mitigation. It detects objects and alerts drivers audibly, visually and physically, applying braking power and reducing engine torque to help diminish collision severity.



Adaptive Cruise Control

ACC helps reduce driver fatigue by maintaining the set speed when the lane ahead is clear and automatically adjusting to maintain a safe following distance when a vehicle ahead is detected.

Mirrors

We didn't change what works. The mirrors on the new 5700XE are heated to fight off frost and fog, and are cab-mounted for easy viewing with little vibration.

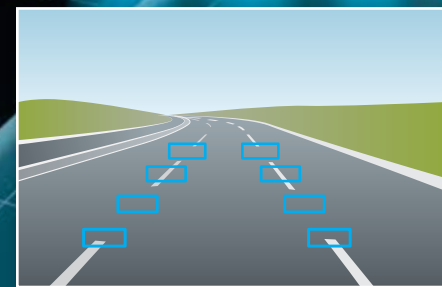

Lane Departure Warning System (LDW)

Even experienced drivers can drift off course. The LDW system helps correct that with audio alerts that indicate if your truck is drifting, and whether it's to the left or right.



ABS with Roll Stability Control

Our Anti-Lock Braking System (ABS) gives you greater control under harsh braking conditions. Add to that our Roll Stability Control, which applies braking to individual wheels for increased safety, or our Enhanced Roll Stability Control, which adds a yaw sensor for even greater stability, and you have one very solid platform.

BOOST UPTIME AND PROFITABILITY EVEN MORE

Detroit Virtual Technician

Our innovative feature transmits critical engine data and diagnostics almost instantly. It identifies problems and lets you know whether it's okay to keep driving or whether you should stop immediately, saving time and money on costly repairs. And should you need service, it will direct you to the nearest location with the needed parts in stock.

Visibility Software

Visibility fleet software delivers real-time data on your entire fleet, making it easier to monitor the status of one or all of your trucks. You can quickly audit vehicle location, speed, routes, idle times and much more. This detailed information will guide you in making adjustments to your vehicles, training and/or routes to provide valuable savings.



Virtual Technician comes standard in all Western Star truck models featuring Detroit™ engines.



THIS IS EXTREME EFFICIENCY

This is aerodynamics and efficiency on a whole new level. We looked at every detail, improving aerodynamics wherever possible, choosing the most efficient drivetrain, and matching it all with the durable components Western Star is known for. It's all aimed at reducing maintenance and repair costs, increasing uptime and lowering total cost of ownership. Because today, having a few curves just isn't enough.

HERITAGE BUILT HERE IN NORTH AMERICA.

Western Star has a long history of ruggedness, of dependability, and of hand-built factory customization that most manufacturers can only hope to match. And like all of our Western Star® trucks, the all-new 5700XE is manufactured in the United States.

At our state-of-the-art Daimler plant in Cleveland, North Carolina, each 5700XE is assembled by hand, using the toughest Western Star components and the most advanced Daimler technology available. It's not the least expensive way to build a truck, but it is the Western Star way.



5700XE

XE EXTREME EFFICIENCY

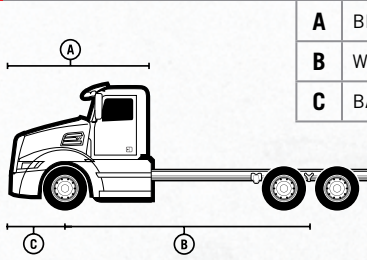

A	BBC: 126"
B	WB: Up to 250"
C	BA: 50"

PARTS AND SERVICE, WHEN YOU NEED THEM.

Our goal is to keep you working. That's why your dealer has an experienced service center team and carries a wide selection of parts, with access to an even greater variety through our expanding global network of parts distribution centers. You get the support you need to grow – no matter where you do business.

YOUR KIND OF FINANCING PROGRAMS.

Being part of the Daimler Truck Financial family means we can get you into the right truck at the right price with rates that are competitive with anyone, including banks. Plus, because we know the transportation and vocational business, it's simple to get the financing you need – and into the Western Star you want.

Daimler Truck Financial

Financing that works for you.

SPEC YOUR OWN MASTERPIECE.

With all the different types of loads there are to haul, it only makes sense to offer the options to create the truck you want. And that flexibility is why we offer three different heights and five lengths. Low or high, long or short, there's a Western Star sleeper configuration to give you as much room as you need.

SLEEPER DIMENSIONS

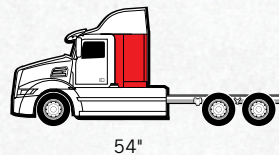
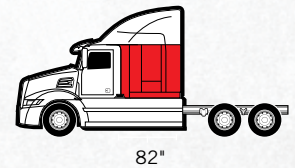
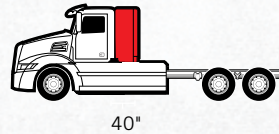
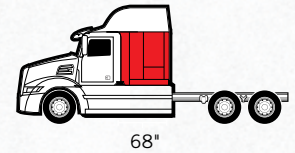
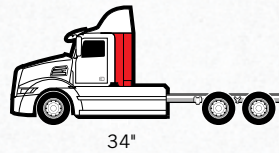

ROOF OPTIONS

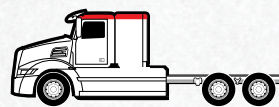

LOW ROOF
Available with 40", 54"
and 68" sleepers.

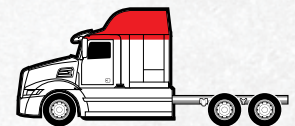

HIGH ROOF STRATOSPHERE
Available with 34", 40", 54", 68"
and 82" sleepers.



ULTRA HIGH ROOF STRATOSPHERE
Available with 82" sleeper.



WESTERN STAR

For the Western Star Dealer nearest you, call 1-866-850-STAR | WESTERNSTAR.COM



WS/MC-B-540. Specifications are subject to change without notice. Western Star Truck Sales, Inc. is registered to ISO 9001:2008 and ISO 14001:2004. Copyright © 2016 Daimler Trucks North America LLC. All rights reserved. Western Star Truck Sales, Inc. is a subsidiary of Daimler Trucks North America LLC, a Daimler company.

DAIMLER | Western Star - A Daimler Group Brand